



# APPS R-12K

## TABLET COUNTER

**VERSATILITY, ACCURACY, AND RELIABILITY** are the hallmarks of the R-12K Tablet Counter manufactured by APPS, Inc.

The advanced twelve-lane counting system of the **R-12K** is capable of counting all types of tablets, capsules and gelcaps, regardless of shape or size.

Fast, easy changeover in under 20 minutes, without the use of tools, is an important feature of the **R-12K**.

The **R-12K's** unique design provides the operator with a clear, unobstructed view of the product, from hopper to bottle. This, coupled with a color-touch screen operator interface, and multi-language capability, creates an effective, user-friendly environment.

*No matter what your product looks like, you can count on APPS, Inc. for fast, accurate results.*



gel caps or capsules • fast, reliable operation  
irregular shapes • large and small tablets  
simple, easy clean-up • compact size, low cost



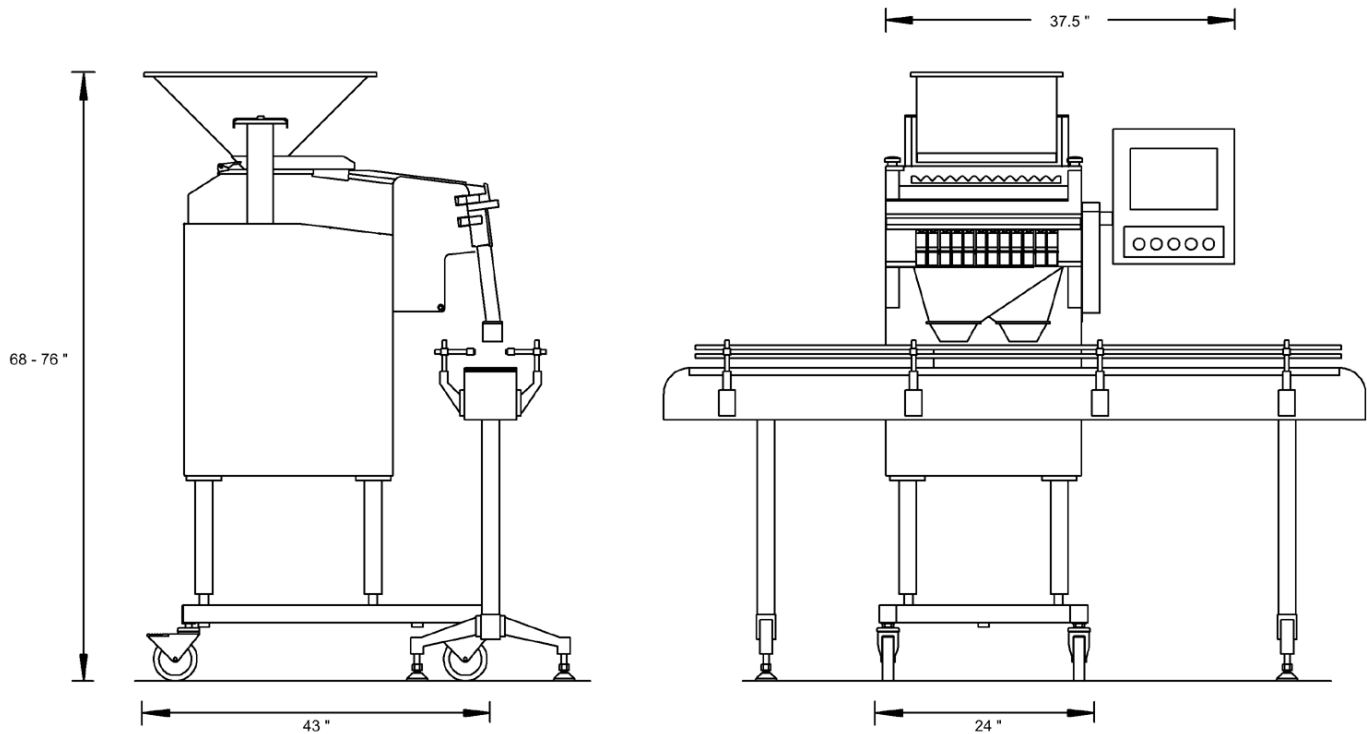

---

## Additional Features

---

- Twelve-lane counting system
- Large 1600 cubic-inch capacity hopper
- Automatic feed control
- Purge mode with bulk counting capability
- Smooth, push-button height adjustment
- Built in dust extraction
- Store recipes and batch logs
- Extra large tablet chutes prevent jam-ups
- Easy to clean — No place for stray tablets to hide
- Built-in casters
- Stainless steel construction
- GMP design
- DESIGNED AND MANUFACTURED IN THE USA

---

## Utilities

---

- Voltage: 120 Volts, 60 Hz, 15 Amps
- Air: 80 PSI @ 1 CFM

---

## Available Options

---

- Automatic reject for incorrect count
- Hopper extension for additional capacity
- Hopper level sensor
- Stack lights
- Static eliminator
- Leveler legs

---

CONTACT US FOR AN HONEST NO-OBLIGATION PERFORMANCE EVALUATION OF YOUR PRODUCT

---



25 North Main Street  
East Templeton, MA 01438  
TEL: (978) 342-0019  
E-MAIL: [tstange@apps-usa.com](mailto:tstange@apps-usa.com)